

8

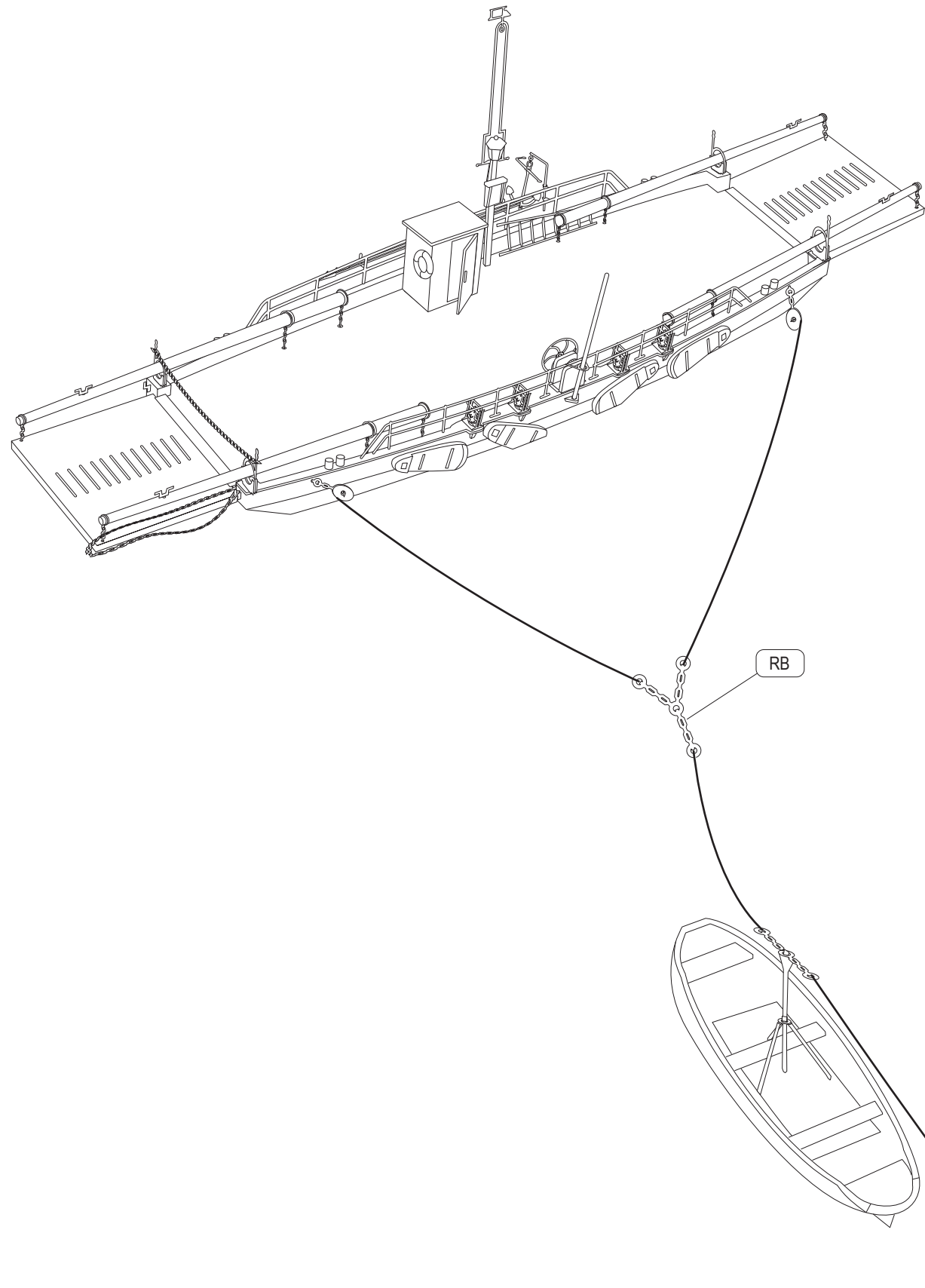

Kleuren / Farben / colors:

- H = Humbrol
- R = Revell
- ***** = a lot
- * = a little

AT - Anthracite

- H33*** + H34*
- R9***** + R5*

OW - Off White

- H34***** + H33* + H24*
- R5***** + R8* + R15*

BG - Blue Grey

- H25**** + Off White*
- R56**** + Off White*

BK - Black

- H33 / R8

WH - White

- H34 / R5

YW - Yellow

- H24 / R15

SR - Scarlet Red

- H60 / R36

LR - Leather

- H62 / R85

BR - Brick Red

- H70 / R37

RB - Rust Brown

- H113 / R37**** + R8*

BY - Brown Yellow

- H24**** + H110* / R88

NW - Natural Wood

- H110 / R86

SV - Silver

- H11 / R191

• Mengverhoudingen:

- *** = veel / viel / much
- ** = evenveel / gleich / equal
- * = weinig / wenig / a little

- Lijm resin en messing onderdelen met seconde-lijm (cyanoacrylaat).
- Zum verkleben verwenden Sie Cyanoacrylate.
- Glue resin and brass parts with Cyanoacrylate.

